

E-ROV:

From Vision to Reality

FFU 2019



equinor





# OrcaFlex buoy simulation @ Hs 4,5 m



equinor

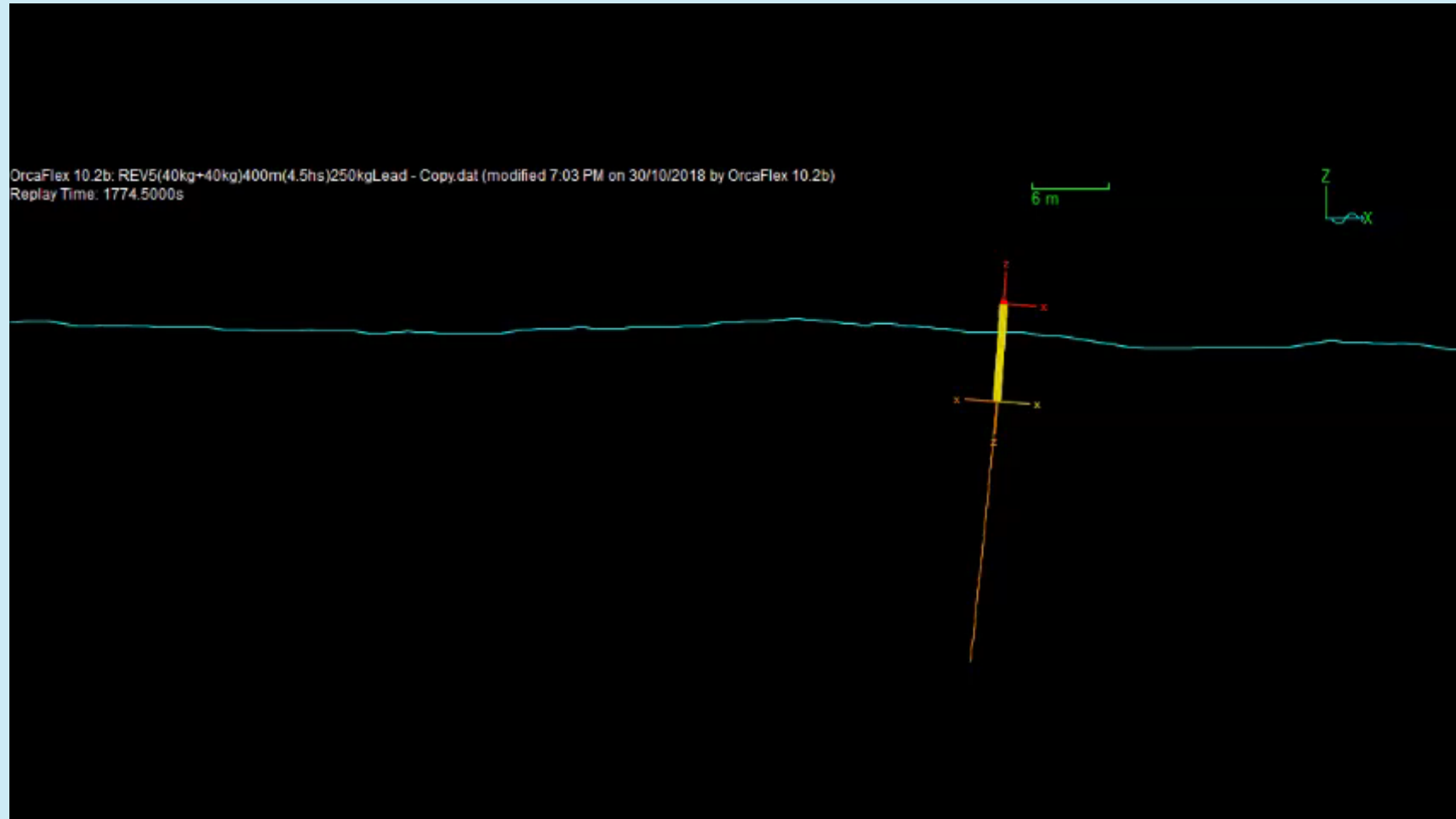

# E-ROV: From Vision to Reality:

September 2015:

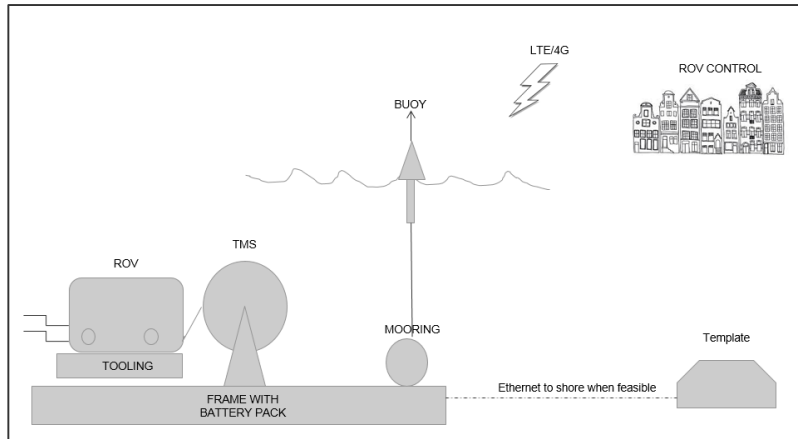

January 2016:

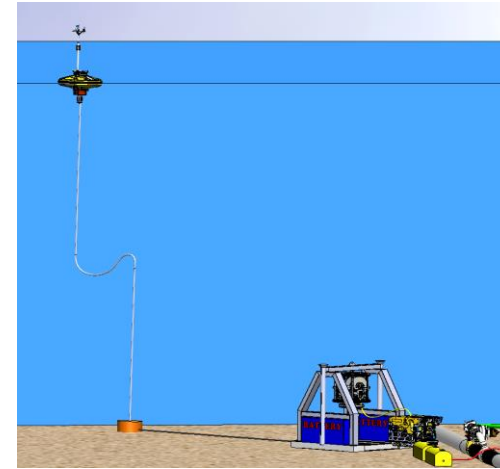

June 2017:



January 2019:



# Award Winning E-ROV

**Spotlight**<sup>SM</sup>  
on new  
**TECHNOLOGY**



E-ROV

## Main Frame

Footprint: 20' container

Weight: 25 tons

Single lifting point

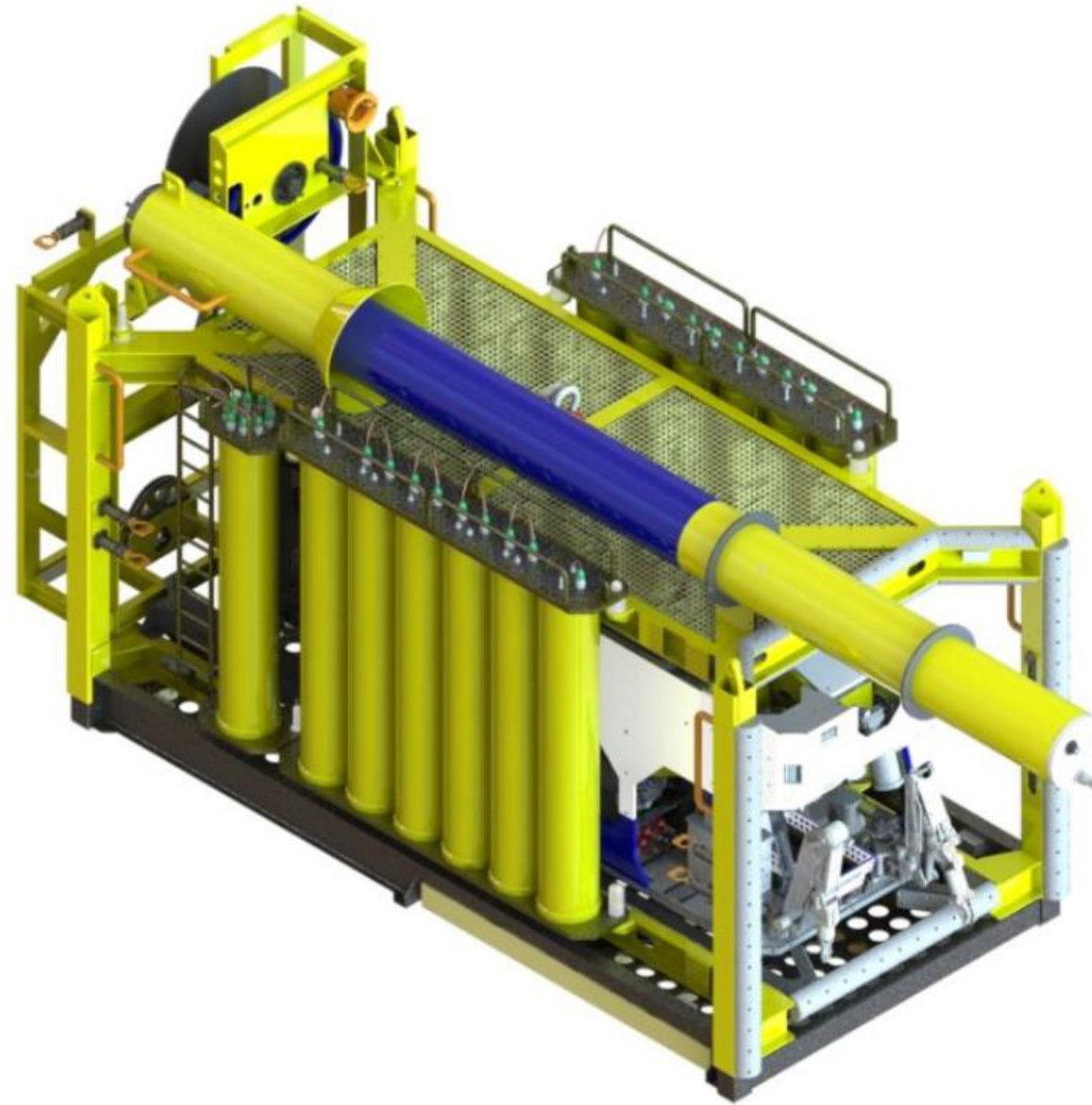

# E-ROV

## Main Frame with buoy system

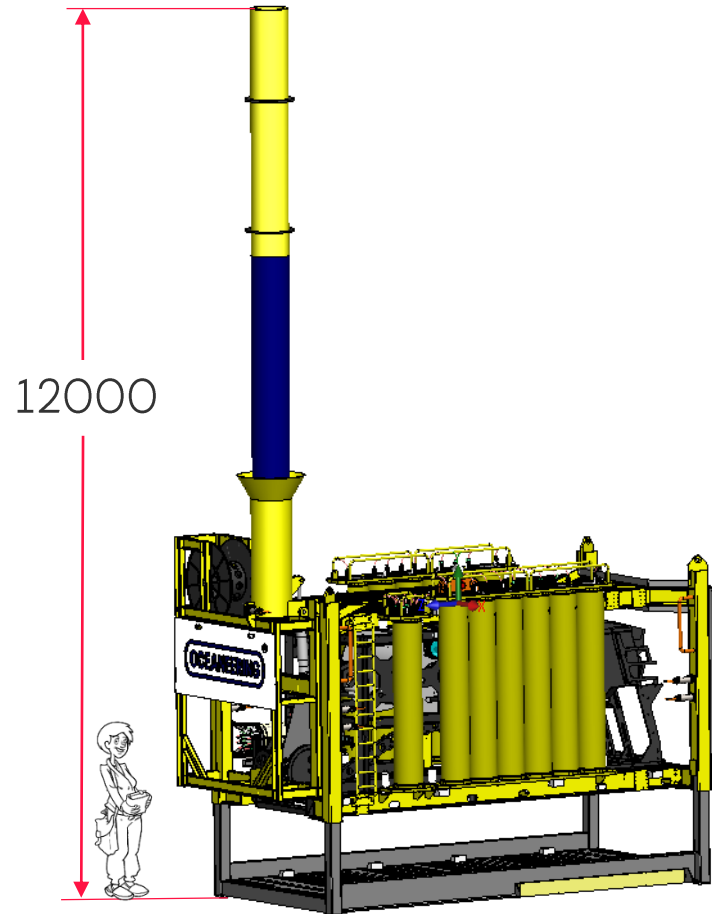

E-ROV

# Main Frame





# TMS Frame



# Testing of the TMS



# The Work ROV

Electrical Enovus WROV

Schilling T4 and Schilling Atlas:  
7f manipulators

HPU for manips and tooling

SPRINT-Nav inertia  
subsea navigation system



# Battery System

50 000 of  
Litium battery  
size  $\text{Ø}18 \times 65$

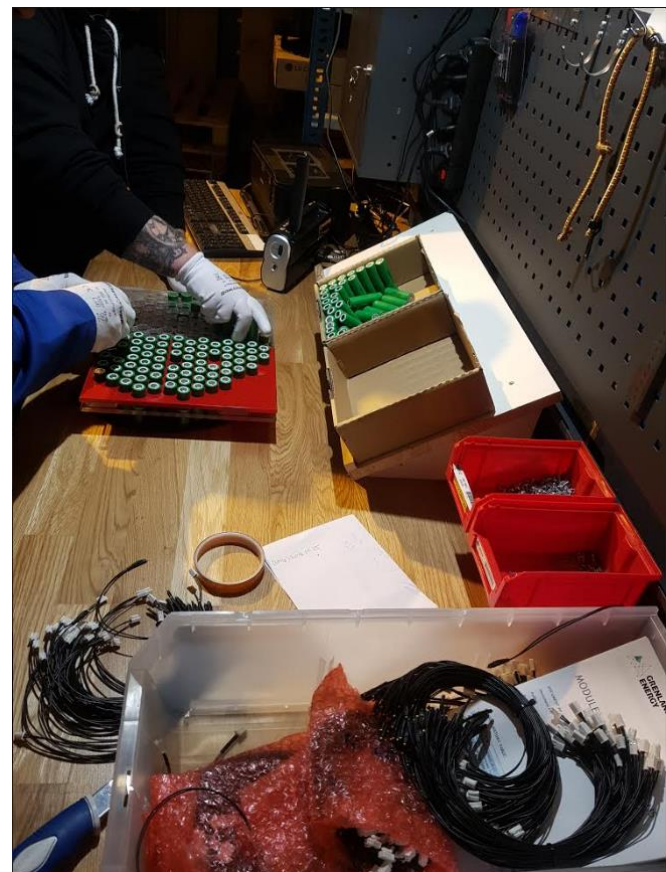

# Battery System

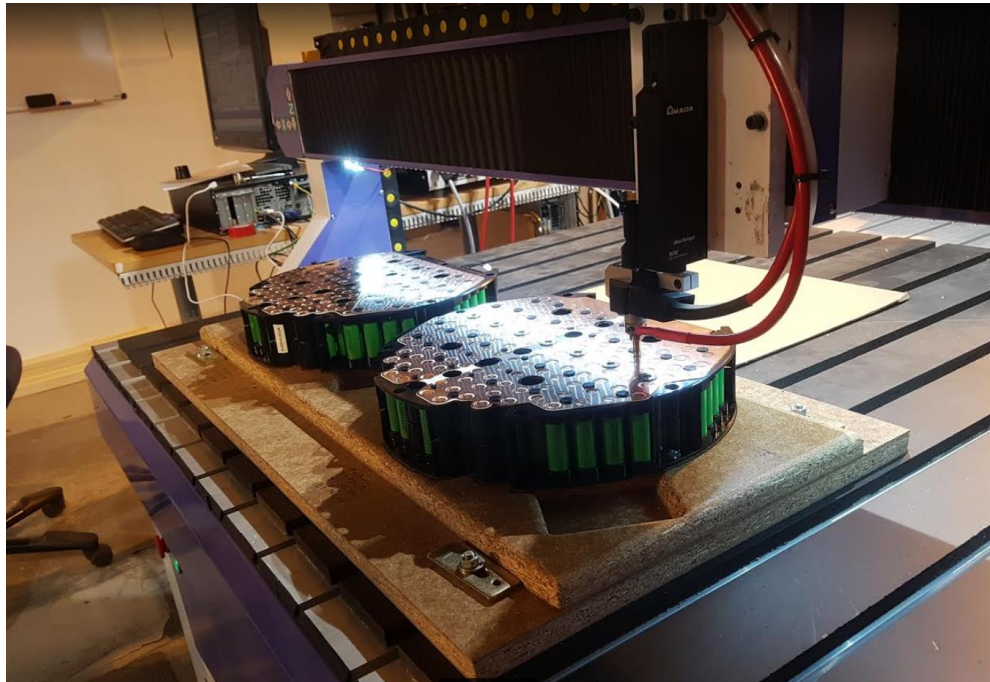

# 500 kWh Battery System

12 of battery  
Canister

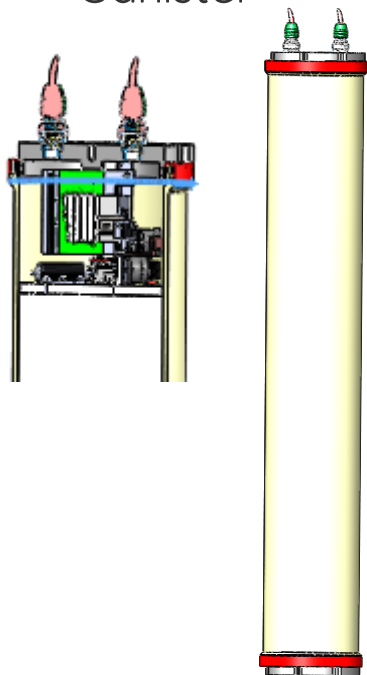

2 of Battery unit

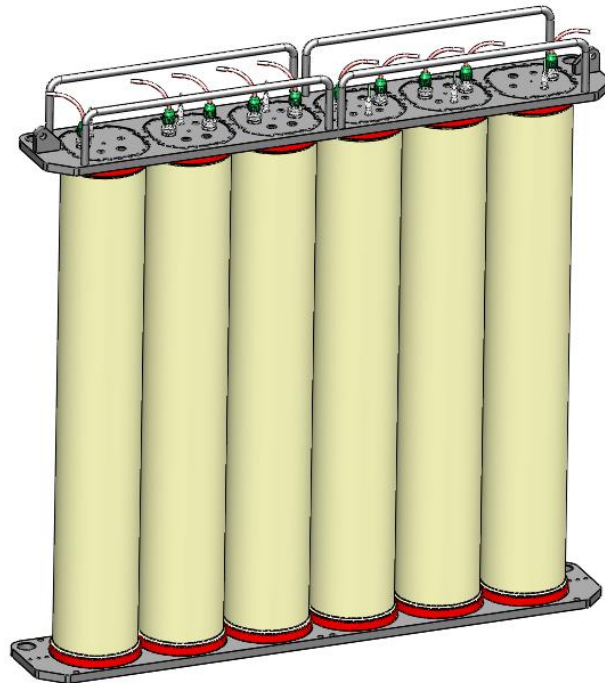

1 of BMS Canister

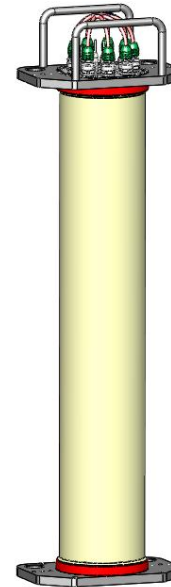

# Battery charger



# Hyperbaric testing





# Transport

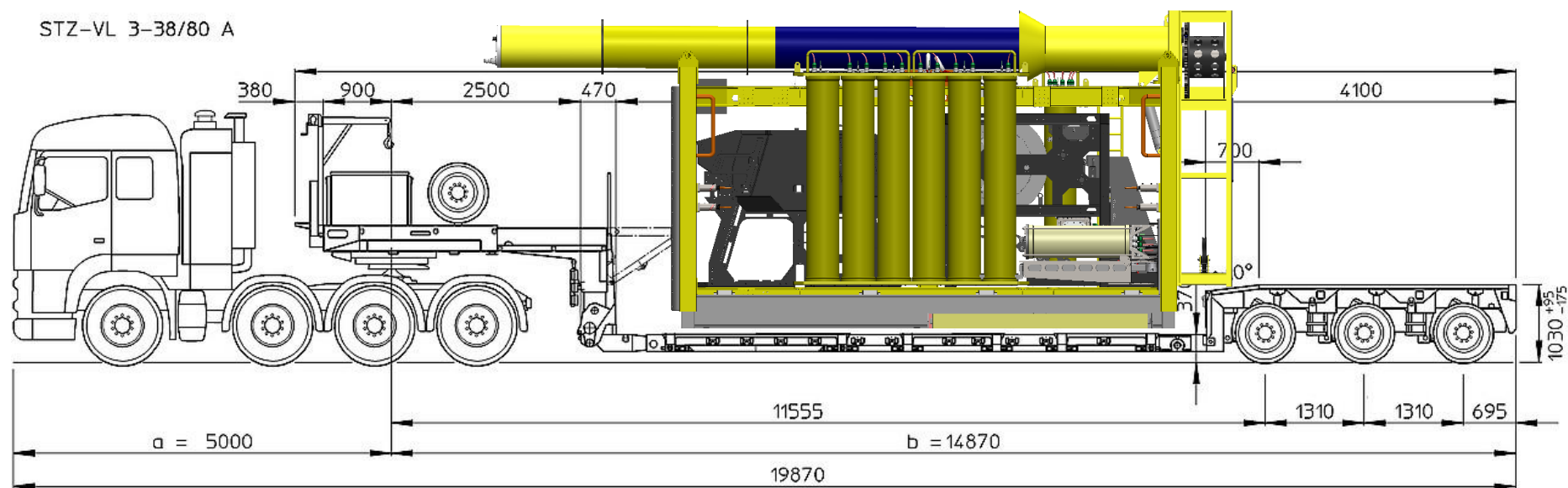

# Fly-out ROV

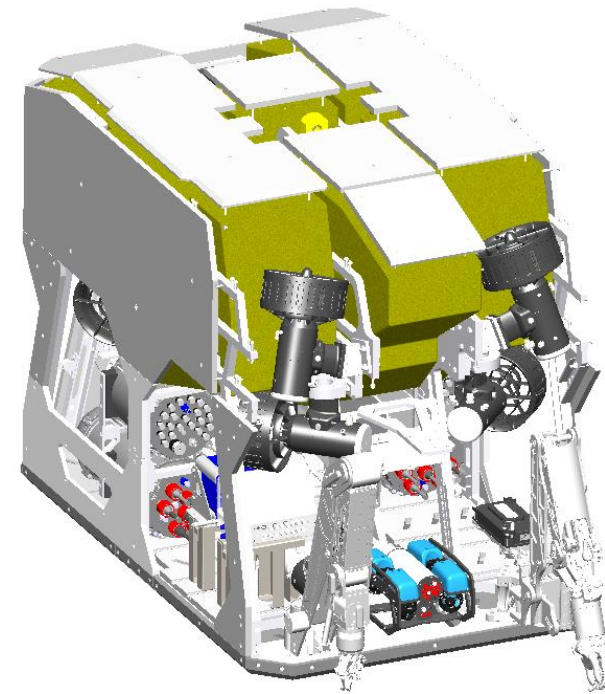
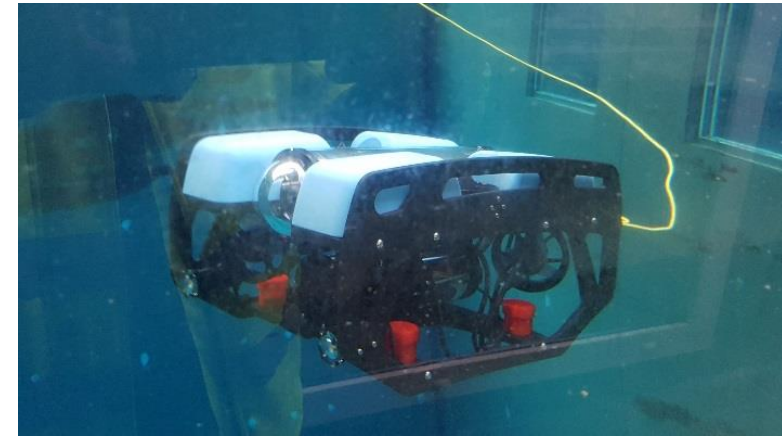

# Typical E-ROV operations

- Manipulator operations
  - Hot-stabbing
  - Jumper change outs
  - De-Commissioning
  - Commissioning
  - Jacket inspection
  - Subsea template inspection
  - Riser inspection
  - Anchor chain inspection
  - Cleaning
  - High pressure jetting operations
  - Valve operations with torque-tools
- RFO/pigging operations
  - CP-probing
  - Condition monitoring
  - Rig support
  - Tie in operations

The E-ROV Concept may also become a valuable tool for other Ocean Space activities such as sea farming and offshore wind operations

# Cost efficient E-ROV operations:

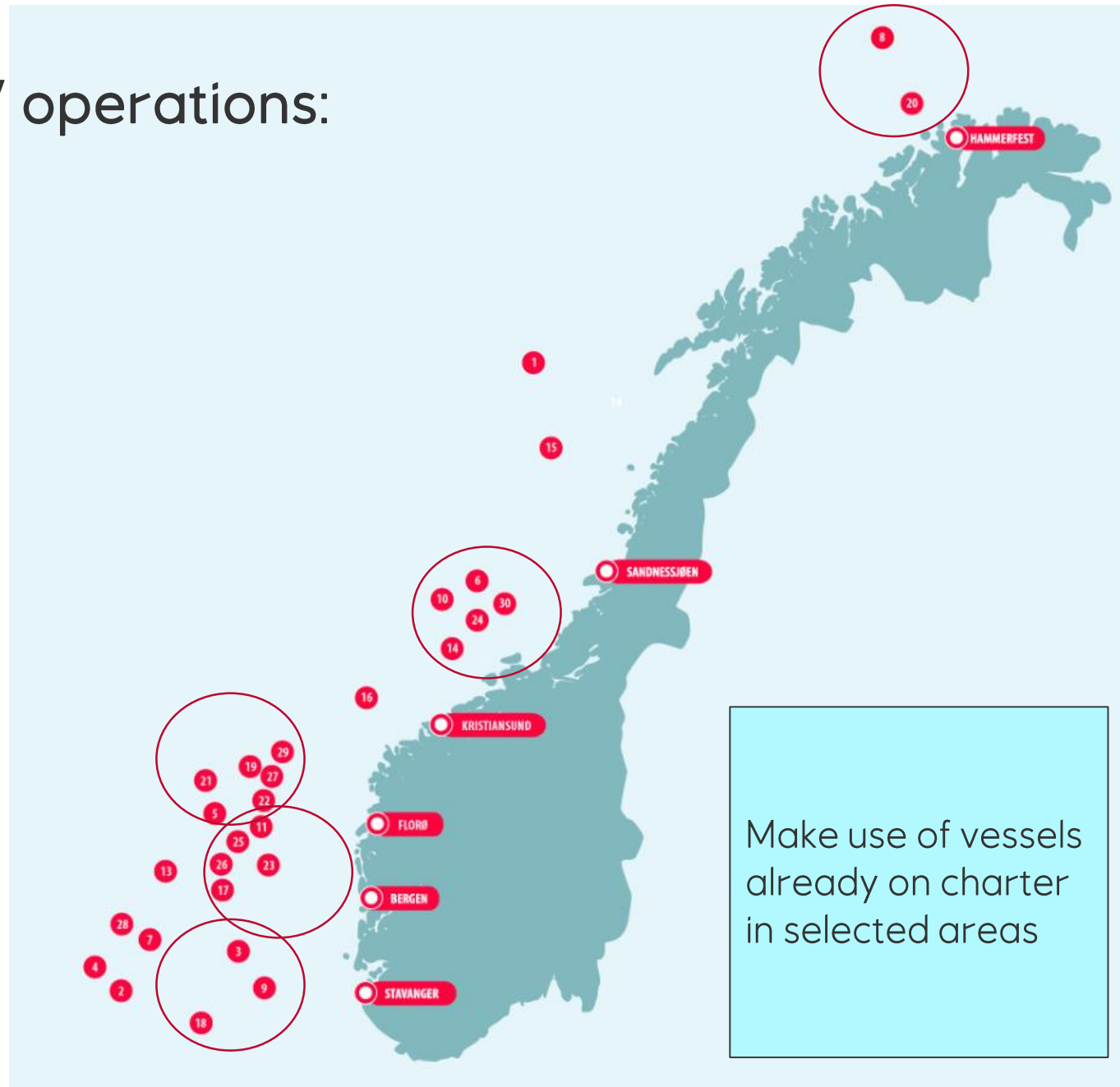

Make use of vessels already on charter in selected areas

# E-ROV = Team Work



There's never been a better  
time for **good ideas**

Kaj-Ove Skartun

Equinor - Subsea IMR

+47 480 80 140

[www.equinor.com](http://www.equinor.com)

